



# Datasheet

## Economy Surface LED Satellite

Cat.No: 659630LI



Operating Mode	Non - Maintained
Nominal Input Voltage	230 - 240 V a.c. 50 Hz
Battery	Li-ion 6.4 V 1500 mAh
Inrush Current	2.6 A peak
Power Consumption	1 W
Light source Life (LSL)	50,000 hrs
Operating Temperature	10°C to 40°C
Construction	Polycarbonate (Satellite head) Zn Steel - White (Body)
IP Rating	IP20
IK Rating	IK08 (Applicable only for metal enclosure)
Product Weight	1 kg
Compliance	AS/NZS 2293, AS/NZS 60598
Product Marking	 

# Economy Surface LED Satellite

Cat.No: 659630LI



## FEATURES

- Suitable for all emergency lighting applications.
- Energy efficient: 1W energy consumption.
- D40 classification
- iSmart™ temperature sensing technology for the Li-ion battery.
- Electronics designed to lengthen the life of the battery, minimising maintenance costs.
- Environment friendly battery.
- Designed in Australia.
- 3 Year Warranty.

## DIMENSIONS

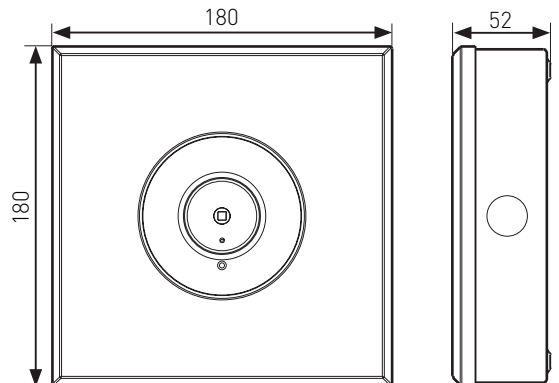

## SPACING TABLE

Maximum Spacing between luminaires for 0.2 lux (Australia)					
Mounting Height (m)	2.7	3.0	3.3	3.6	4.0
D40	14.8	16.5	18.1	19.5	20.1

As per AS/NZS 2293.1:2018

Maximum Spacing between luminaires for 1.0 lux (New Zealand)					
Mounting Height (m)	2.7	3.0	3.3	3.6	4.0
D40	9.9	10.1	10.2	10.3	10.3

As per AS/NZS 2293.1:2018

**Note:** All the dimensions are in mm.

Legrand Australia  
1300 369 777  
www.legrand.com.au  
ABN 31 000 102 661

Legrand New Zealand  
0800 476 009  
www.legrand.co.nz

Refer to your group buying office, Legrand Sales Representative or Legrand Sales Office for pricing.

Please note: specifications are subject to change without prior notice.



LE18046AA

04/2021